



HEATING & DHW

Gas Fired Absorption Heat Pump (GAP)



V20

AIR SOURCE GAS
FIRED ABSORPTION
HEAT PUMP (GAP)



VICOT SOLAR TECHNOLOGY CO., LTD.

Add: Hongdu Road, Dezhou Economic
Development Zone, Shandong, China

Tel: +86 531 8235 5568/5566/5752

Fax: +86 531 8235 7911

Email: export@vicot.com.cn

www.vicot.com.cn



MESSAGE FROM PRESIDENT

To make our private life be meaningful, make products and service good for society and benefiting our staff & society is Vicot founders common sense in our mission and honor at the beginning of Vicot establishment. Vicot has been having many supports from friends and clients and growing up in the market, basing on the pursuit of life meaning and enterprise value. With those precious supports, we deeply understand a person or a team who is striving for dream is not alone in the process of adventure. The gas and/or solar fired air source absorption heat pump (GAP) and solar boiler as Vicot R & D achievement from many years' of intelligence, vigor and capital input, perfectly express Vicot' s pursuit of value.

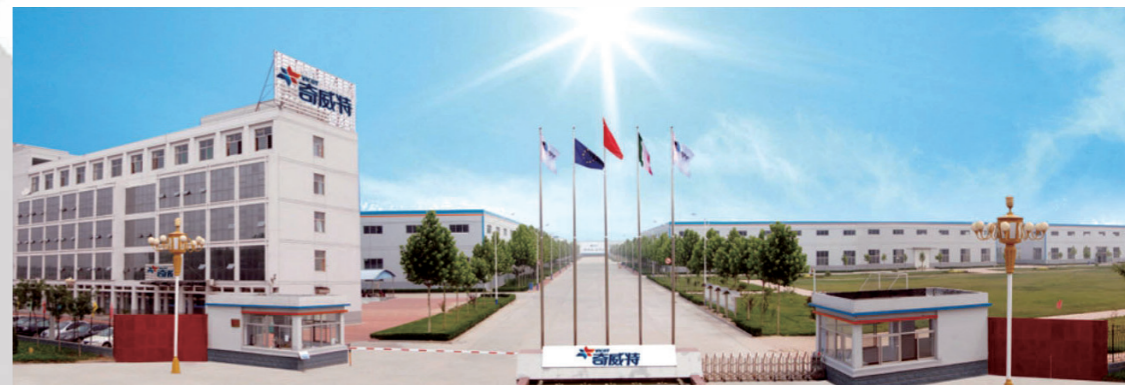

GAP represents the most advanced productivity, broke the limit of solar and air source energy industry, combines three types of clean energy in the commercial and industrial application in the same time, extends the application field of clean energy in a milestone way and proves Vicot capability of creating industry benchmark with its technology patent achievements. GAP also stands for the clean energy' s increasing powerful impact to human daily life, the earth is for us and for our next generations also, clean energy will become the prevailing main energy with its incomparable advantage of environment protection and serve more people, more districts and benefit the planet environment.

There were many difficulties in the process of the R&D and manufacturing of new products, but we remained in firm confidence. We are sure that we will win a better tomorrow no matter how painful is the process, because we have the industry technology and production experience accumulated in many years and the pursuit of product value. Now, the era creating product is right here, it stands for bigger market, more harmonious relation between human and nature and more magnificent behavior. Those new products in the clean energy industry will bring the true sense of honor to their innovator, manufacturer, distributor and user. We are striving for a better earth!

CORPORATE CULTURE

MISSION:

ONE DREAM ONE TEAM
FOR STAFF FOR SOCIETY

VISION:

THE SAME BREATH
ENERGY SAVING TOGETHER

KEY CAPABILITY:

SATISFY THE CLIENTS'
DEMAND OF VALUE
CREATIVITY QUALITY SERVICE
SOCIAL RESPONSIBILITY

VICOT CERTIFICATE & AWARD

- 01 2010: Verification report proves that Vicot's research has obvious and international leading creativity and benefit of energy saving and environment protection, issued by Shandong Economy & Information Committee.
- 02 2010: Scientific Technology Achievement verification certificate awarded by Shandong Provincial Science & Technology Department
- 03 2011 National Energy Science Progress 3rd Prize award by China National Energy Administration
- 04 Assessment report issued by Construction Environment & Equipment Branch of China Engineering and Consulting Association, concluded that Vicot's research has technology creativity with obvious benefit of energy saving and environment protection, is a significant breakthrough and reaches international leading level.
- 05 2013 Shandong Construction Technology Creation 1st Prize
- 06 2013 Vicot participates the Solar Cooling Research of "The 12th Five Year Plan" National Science and Technology Support Scheme
- 07 2013~2014 150 nos. of national invention patent and utility patent approved
- 08 2015 National Construction Committee Science Progress Prize awarded
- 09 2015 The 4th time of "Quality Management System Certificate" and "Environment Management System Certificate" approved.



GAP PATENT LIST

No.	Description	Patent No.
1	A solar and air source type absorption heat pump device	ZL 2012 1 0361473.5
2	Solar direct driven ammonia water absorption air source heat pump air conditioning system	ZL 2012 2 0597315.5
3	A complete metal type frame box for air conditioning unit	ZL 2013 2 0054212.9
4	An absorption heat pump with auxiliary defrost	ZL 2013 2 0055451.6
5	A modular type absorption air conditioning unit	ZL 2013 2 0055417.9
6	Manifold and absorber	ZL 2015 2 0848297.7
7	Generator, water storage device and absorption type gas heating device	ZL 2015 2 0846616.0
8	Rectifier	ZL 2015 2 0846571.7
9	Water circuit in heating system	ZL 2015 2 0874295.5
10	Combustion chamber base and burner	ZL 2015 2 0874356.8
11	Orifice assembly	ZL 2015 2 0909833.X
12	Combustion chamber and generator	ZL 2015 2 0915187.8
13	Threaded tube type absorber	ZL 2016 2 0090436.9
14	Dual energy absorption type air conditioning unit	ZL 2016 2 0024695.1
15	Direct fired type high efficiency generator	ZL 2015 2 1056377.5
16	Heat recovery device in absorption unit	ZL 2016 2 0026849.0
17	A hollow pipe scoring machine	ZL 2016 2 0090439.2
18	Threaded tube type absorber and its manufacturing method and manufacturing equipment	ZL 201610062176.9
19	A working medium concentration control method for gas fired absorption heat pump m	ZL 201610024760.5
20	Heat recovery device for absorption unit	ZL 201610018826.X
21	Dual energy absorption type air conditioning unit	ZL 201610017203.0
22	Combustion chamber and generator	ZL 201510788823.X
23	Combustion chamber base and burner	ZL 201510742380.0
24	Pressure control method, device in hot water supply circuit and hot water supply circuit	ZL 201510744259.1
25	Metal anti corrosion substance and its application	ZL 201510732054.1

V20

V20 PERFORMANCE AND APPLICATION

SHORTNESS
Efficiency is only around 90%



GAS BOILER

SHORTNESS
• Driven by secondary energy, electricity, the energy cost is high and consumption is huge.
• Not able to start normally when ambient temperature is low
• Adopts HFC refrigerant, harmful to environment.



ELECTRIC COMPRESSOR TYPE AIR SOURCE HEAT PUMP

ADVANTAGE
Driven by primary clean energy natural gas, energy cost is lower

ADVANTAGE
Adopts heat pump technology, gets air source energy freely



V20



Radiator



Floor heating



Fan coil unit



- Feature:**
1. Optional built in high efficient water pump.
 2. Built in weather compensation control mode, unit operation with higher efficiency.
 3. Built in anti-freezing function.

V20 ADVANTAGES

UTILIZATION OF NATURAL GAS AND AIR SOURCE ENERGY,
GOOD FOR ENVIRONMENT PROTECTION

>> Good for environment protection

■ Each V20 GAP unit can annually save **19.345** tons of standard coal,
Reduces **47.782** tons of CO₂ emission,
in equivalence of planting **2611** trees.

■ Vicot produces **12,000** sets of V20 GAP unit,
It can save **232,140** tons of standard coal,
reduces **573,384** tons of CO₂ emission,
in equivalence of planting **31,332,000** trees.



THE ADVANTAGES OF V20

V20 ADVANTAGES

LOW OPERATION COST

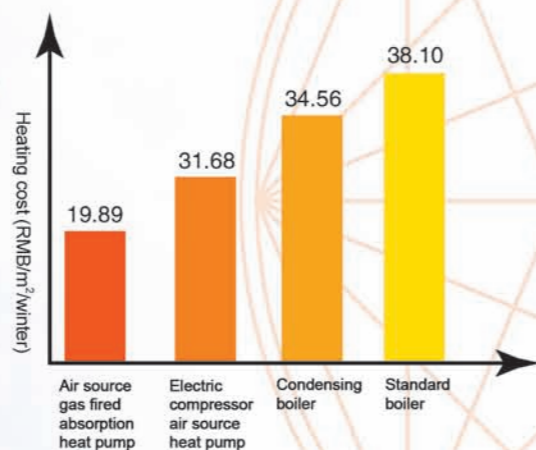

Item	Air source gas fired absorption heat pump	Electric compressor air source heat pump	Condensing boiler	Standard boiler
Renewable energy	Air	Air	No	No
Heating cost (RMB/m ² /winter)	19.89	31.68	34.56	38.10

Remark: The above data is based on the heating in Beijing, design load: 50 W/m², supply water temp. 50°C, electricity cost: RMB0.55/kWh, natural gas cost: RMB3/m³.

LOW EMISSION

- (1) GAP adopts heat pump principle, natural gas consumption amount is 45% of conventional boiler, and emission is reduced by 55%.
- (2) GAP adopts advanced premixing combustion technology, the nitrogen oxide emission is in international leading level.
- (3) SO₂ emission concentration 9 mg/m³, NO_x emission concentration 27 mg/m³, particle concentration 2.3 mg/m³, smoke blackness <1 Ringelmann.



REMOTE CONTROL, WORRY FREE OPERATION



There is an intelligent built in CPU in each GAP before leaving factory, the operation status of GAP can be monitored and operation parameter can be set through internet in our headquarter, to ensure the unit operation performance and in economic consumption status and save the operation cost; it is optional to check the maintenance at site and keep the client away from worry of operation; the unit self-diagnosis function can be controlled and unit will have self-diagnosis after operation of certain period and adjust the problem occurs during operation.

V20 ADVANTAGES



“FROST FREE” HEAT PUMP



Heavy frost on electric air source heat pump



V20

- (1) Adopts brand new anti-frost technology, prevent the formation of frost and effectively extend the frost interval up to more than 3 hours.
- (2) Defrost energy consumption is reduced to below 5%.



CAPABLE OF OPERATION IN AMBIENT -30 °C

Unit operation ambient temperature range is from -30 °C to 43 °C, not afraid of low ambient temp.



INTELLIGENT CONTROL, STEPLESS CAPACITY ADJUSTMENT

The unit starts in low frequency and operates in high frequency to reach the set temperature quickly. The unit will operate in low frequency to maintain the room temp. when the set temp. reached, the room temp. is constant and more comfortable.



SUPER QUIET OPERATION, THE QUIETEST HEAT PUMP IN MARKET

- (1) No compressor is used, much quieter than electric air source heat pump.
- (2) Adopts optimized fan blades, dramatically reduces operation noise.
- (3) Adopts vibration isolator at base, suitable for installation on ground and rooftop.

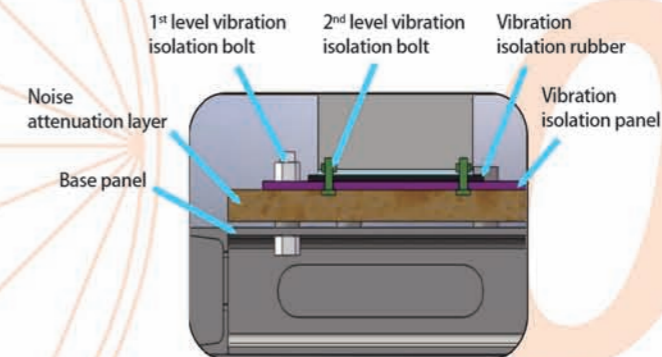

TOTAL HEAT RECOVERY, HIGHER EFFICIENCY

- (1) System thermal energy utilization at high efficiency and more energy saving.
- (2) Unique insulation design of heat exchanger, more safety.

GAS FIRED ABSORPTION HEAT PUMP (GAP) VGAHR020 (V20)

Notes:

1. Nominal heating capacity: ambient dry bulb temperature 7 °C, ambient wet bulb temperature 6 °C, water outlet temperature 45 °C, there will be certain change of heating capacity in different ambient temperature;
2. Natural gas lower heating value 34.02 MJ;
3. Test condition: natural gas static pressure 2.5 kPa;
4. The noise value is the average value in 5 meters away from the unit;
5. The specification is subject to the value in rating label, and no prior notice before any change.

Item	Unit	Specification	
Nominal heating capacity	kW	19.2	
Water flow rate	m³/h	≥1.6	
Water side pressure drop	kPa	≤20	
Minimum water inlet temp.	°C	9	
Maximum water outlet temp.	°C	65	
Ambient temp.	Max. temp.	°C	43
	Min. temp.	°C	-30
Rated thermal input	kW	9.4	
Thermal input adjustment range	kW	3.8-11.3	
Rated natural gas consumption	m³/h	1.0	
Natural gas consumption adjustment range	m³/h	0.4~1.2	
Power supply		220V / 1Ph / 50 Hz	
Electricity power input	kW	0.35	
Unit weight	kg	540	
Noise	dB(A)	40	
Pipe size	Water pipe (threaded)	In	DN25
	Gas pipe (threaded)	In	DN15
Unit dimension	Length	mm	1600
	Width	mm	950
	Height	mm	1710

V20 heating performance curve

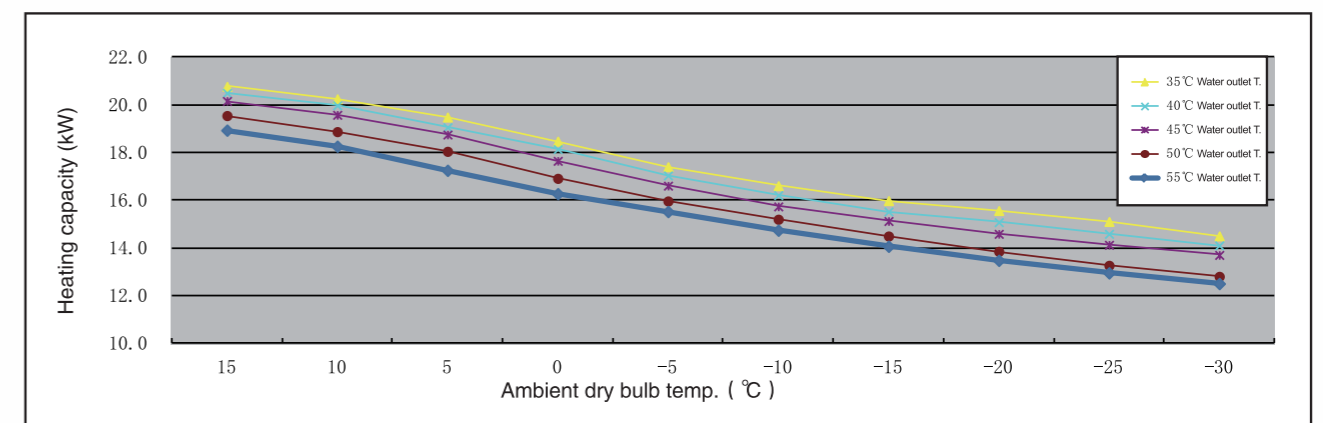

INSTALLATION INSTRUCTION

Installation space requirement

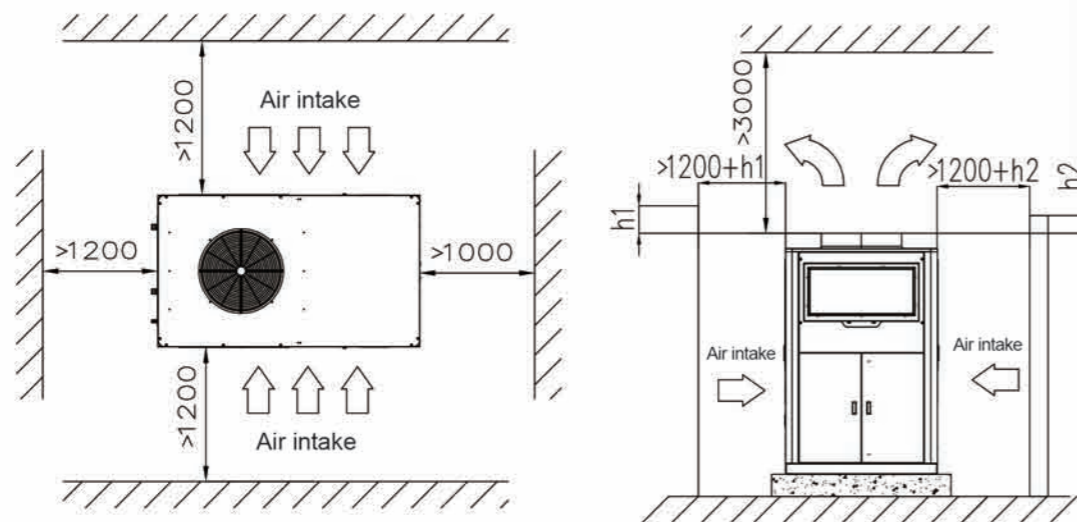

Minimum surrounding space diagram

Foundation

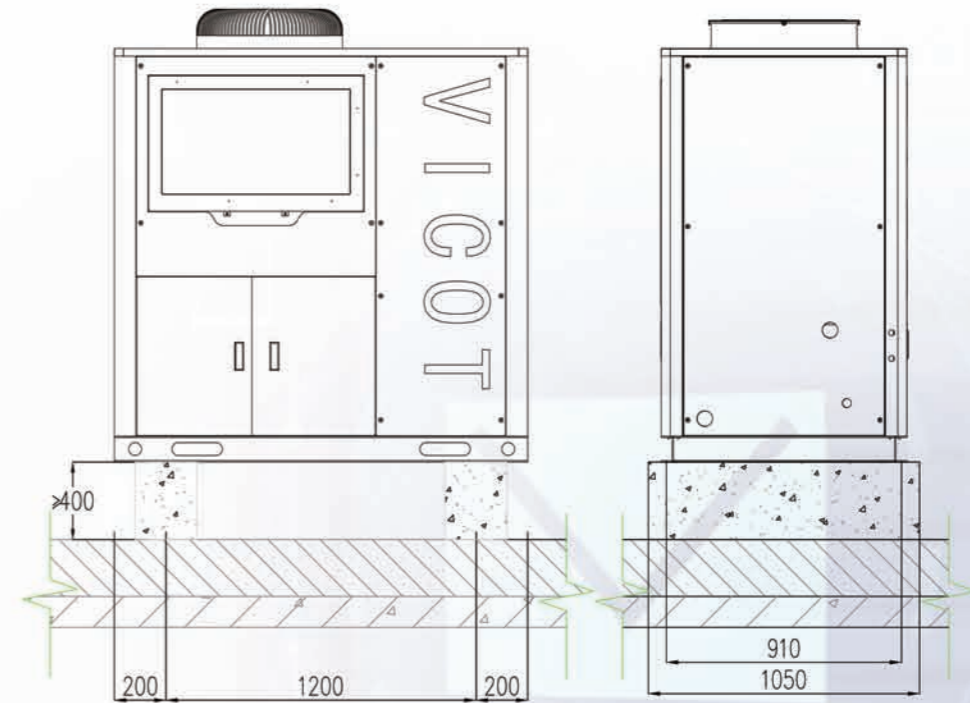

Notes:

1. Foundation must be qualified for the unit weight.
2. Foundation height should be more than 400mm, so as to keep snow accumulation away from unit in winter.
3. Foundation levelness should be < 2 mm/m.
4. Ensure rain water and condensed water drainage around the unit.
5. No barrier placed in the ventilation area.
6. Avoid unit noise and smoke impact to resident.

System principle diagram

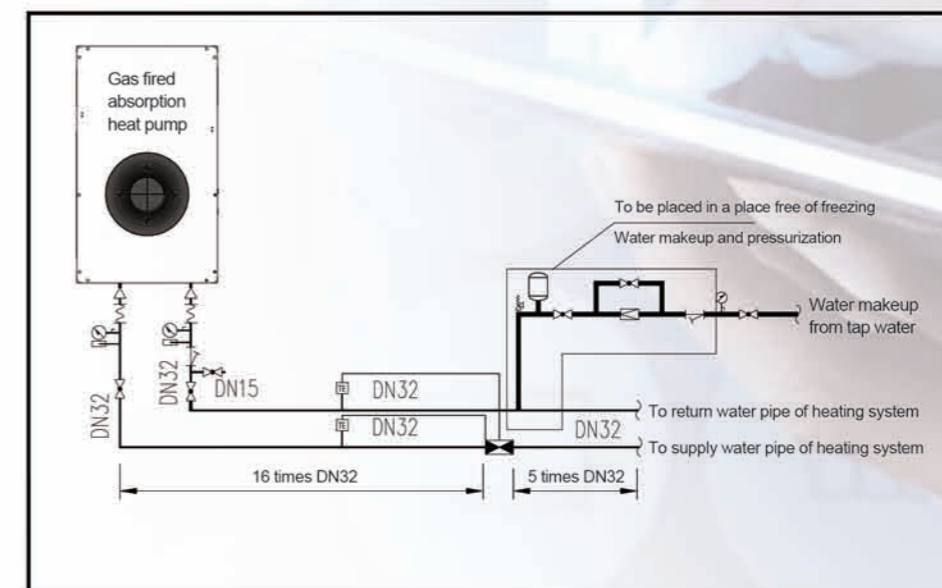

PIPING INSTRUCTION

The following principle should be followed during water piping installation:

- 1) Water pipe length should be as short as possible;
- 2) The piping accessories should be installed strictly as per drawing;
- 3) The water pipe should not be less than DN32 at the connection part to unit, the system total water piping system resistance should be less than 7 meters;
- 4) Keep the elbow nos. as less as possible, and have elbow radius as big as possible;
- 5) The insulation thickness should not be less than 30 mm for pipe installed at outdoor.

Water circuit installation steps:

- 1) Install the water pipe and accessories.
- 2) Leakage test with pressure: Carry out water pressure test after pipe installation, the testing pressure should be 1.5 times of that of working pressure and no less than 0.6 MPa.
- 3) Inspection method: The water pressure drop no less than 0.05 MPa with testing pressure in 10 minutes, then reduce working pressure and no leakage in working pressure. Flush the system repeatedly till there is no sand, no scratch in water and water is clear after the leakage test. All the strainer should be removed before flushing and installed again after flushing.
- 4) The outlet water should be same as inlet water in the water color and transparent degree.
- 5) Have auto airvent valve at the highest point of the system.

6) Have flexible connector, pressure gauge, thermometer, valve at the water inlet and outlet pipe of the unit, pressure gauge accuracy 1.6 class and measurement range 0–1.0 MPa, and install T-cock valve there to keep the water pressure gauge away from freezing. Select thermometer with 0~70 °C measuring range and division value 1 °C, upper part length 220 mm, lower part length 40 mm. Have strainer with mesh of 30~40 at the water inlet and outlet pipe of the unit.

7) Install water make up and pressurization unit as per system diagram and have it installed at indoor for anti-freezing.

8) Drain valve or drain pipe should be installed at the lowest position of water inlet pipe, drain water should flow to drain groove.

Electric wiring:

Unit power supply is 220 V, 50 Hz (60 Hz optional)

All wiring and earthing must be in compliance with local electric regulation.

Warning

- Check the electric parameter on rating label and ensure the wiring is carried out as per local regulation.
- The unit should have independent power supply with current breaker and electric leakage protection device.
- Installer should select the power supply according to the unit power input and current.
- All the unit must be earthed.
- The manufacturer is not liable for the problem caused by the wiring change inside of the unit without authorization.
- Earthing must be properly fixed.
- Not to connect the power supply before all the wiring is done to avoid injuries and deaths.
- The power supply voltage fluctuation should be within +7%, –10%.

REFERENCE PROJECTS



>> PROJECT IN HUIAIROU, BEIJING

- Installation site: A villager's house in Huairou, Beijing
- Equipment selected: 2 nos. of V20
- Actual heating area: 300 m²

ABOUT VICOT GROUP

Vicot Group is a high-tech corporation specialized in R&D, production, sales and service of new energy products;

Our production base locates in Solar City, Dezhou, China, has RMB600 million asset, designed annual production value reaches RMB5 billion;

Vicot main products are gas fired absorption heat pump (heating/hot water), solar boiler, solar absorption chiller, solar central heating system, solar central hot water system etc;

Vicot is awarded for many honors such as National Energy Progress 3rd Prize, China Huaxia Construction Science Technology Prize and National Construction Committee Science Progress Prize.

Vicot has 150 nos. of national invention patent and utility patent approved or in the process of approval, and certificates of ISO9001 quality management system and ISO14001 environment management system. The product with international level quality is ensured with strict process control and complete quality management system;

With the vision of “one world, one blue sky” , the corporate focuses on effective utilization of solar energy, air source energy and other renewable energies in construction energy saving heating and industrial energy saving thermal application, strives for technology creation achievement of international new energy application industry.

In accordance with the mission “One Dream, One Team, For Staff, For Society” , Vicot group will make continuous progress in the new energy field and sincerely cooperate and make progress with all the social sectors with quality product, perfect service with a broad mind in a great and firm spirit, and dedicates to creating a happier and richer future for partners, clients and our earth.